



LG400

Alutec Expert
Alutec Competition
Alutec Basic
Anatomic
cal. .177 (4,5mm)

Marketing/Vertrieb
Carl Walther GmbH Sportwaffen
P.O.BOX 27 40, D-59717 Arnsberg
Tel. +49 29 32/6 38-100
Fax +49 29 32/638-149

Service/Technik
Carl Walther GmbH Sportwaffen
P.O.Box 43 25, D-89033 Ulm
Tel. +49 7 31/15 39-0
Fax +49 7 31/1539-109

Preface:

Dear Sports Marksman/Markswoman,
Thank you for choosing one of our products. The new LG400 product series combines the latest innovations with time-tested technology. This is a sports rifle of the highest quality, which we are sure will define sports weapon standards. May your new air rifle give you lots of pleasure and contribute to your sporting success. Good shooting!

Your WALTHER Team

Please note without fail:

Before you use your air rifle, please familiarize yourself with the operation and functioning using the operating instructions. Even the safest weapon can be a danger to you and others if handled incorrectly. Always hold the rifle so that it cannot endanger anyone. Even an unloaded weapon must basically be treated as if it were loaded.

Improper handling and lack of proper maintenance can impair the function and safety of your weapon.

Interference with the mechanism, damage resulting from the application of force and modifications by third parties release the manufacturer from all warranty claims.

Work on weapons may only be performed by experts. Have your weapon checked for safety and function regularly by a recognized specialist dealer.

These instructions must always be included if the pistol changes hands.

Arms must always be kept so that they are out of reach of unauthorized persons, especially children.



Warning:

The trigger pull weight of sporting arms can be finely adjusted. **If the trigger pull weight is set too low**, a shot can be released even if the trigger is only lightly touched or if there is an impact on the weapon.

Please also always observe the legal regulations effective in your country for the use of sporting arms.

CONTENTS

1	Important information on handling firearms (safety instructions).....	33
2	Warranty provisions	35
3	Care	35
4	Cocking and loading / loading status indicator	35
5	Unloading	37
6	Trigger	37
7	Setting for dry firing	39
8	Sights	40
9	Compressed air supply / compressed air cylinder	41
10	Changing the butt stock / cast (Alutec only).....	44
11	Adjusting the butt plate and stock length.....	45
12	Adjusting the cheek piece	46
13	Adjusting the grip	48
14	Fore-end elevation for shooting in the standing position.....	50
15	Fore-end for shooting from a rest.....	51
16	Chest rest for butt plate.....	53
17	Accessories.....	53
18	Equipment / special accessories	54
19	Technical data	56

1 Important information on handling firearms (safety instructions)

The following safety regulations must always be observed by firearms owners. Safe handling of firearms is absolutely necessary for your own safety and the safety of others.

Fully familiarize yourself with the technical properties of the firearm, and learn how to handle and operate it correctly.

Not all guns work the same way (especially with regard to the trigger, loading and unloading); you should therefore spend plenty of time getting to know the characteristics of your gun.

Always keep the muzzle pointed in a safe direction.

Never point the muzzle towards yourself or another person, even in dry training or in procedures such as loading or unloading. A safe direction means a direction in which no person or animal can be endangered and in which there are no objects which can ricochet the round or be penetrated.

Firearms must always be unloaded if they are not going to be used immediately.

If a gun is not going to be used immediately, it should never be kept loaded. Firearms and ammunition must be kept stored safely separate from one another, out of sight and reach of third parties, especially children, visitors, etc. The owner must ensure that unauthorized parties do not come into contact with the gun or the ammunition.

Ensure that the barrel is free of foreign matter, dirt, grease, oil, water, etc. before firing.

Even a small amount of dirt, excess grease or oil can damage the barrel and endanger you or others present. Always be sure that your ammunition is correct for the gun that you are using, in the correct caliber and in flawless quality.

Before shooting, ensure that your target is perfectly safe.

Never shoot before you are fully certain where the projectile will hit. Make completely sure that the round will be stopped directly behind the target, because it is still dangerous even at long distances. Take plenty of time to be absolutely sure before you pull the trigger.

Always wear eye and ear protection when shooting.

Every shooter and every person in the immediate vicinity must wear protective goggles and ear protectors; the noise can damage your hearing.

Never carry a loaded firearm on your person.

Only load the firearm immediately before it is to be used. Never drop or throw a loaded firearm.

Never shoot at a hard surface or at water.

The rounds could ricochet uncontrolled and injure you or a third party owing to their very high energy.

Never transport a loaded firearm.

Firearms must always be unloaded before being transported. A purpose-built case or sheath should be used for transporting firearms to and from the firing range.

Firearms must never be used if alcohol or other drugs have been consumed.

Alcohol, medication and other drugs affect your judgment, your physical condition and your ability to think and act. Such firearms use is punishable by law.

2 Warranty provisions

Improper alterations of the mechanical workings, damage caused by force and alterations by third parties release the manufacturer from all warranty claims. Work on firearms may only be performed by specialists in this field.

3 Care

The metal parts must be treated after use for moisture with an acid-free gun oil. The moving parts, especially striker and valve parts, have been treated at the factory with a long-life grease and don't have to be greased again. The interior of the barrel may only be cleaned using the Walther Cleaning Set (269 82 77) or standard felt pellets, which are shot through the barrel. Under no circumstances should you pass a cleaning rod through the muzzle into the inside of the barrel. Have your sports gun maintained regularly by a specialist to guarantee long-term flawless functioning.

4 Cocking and loading / loading status indicator

When the loading lever is cocked, the loading pin opens the loading recess and cocks the striker.

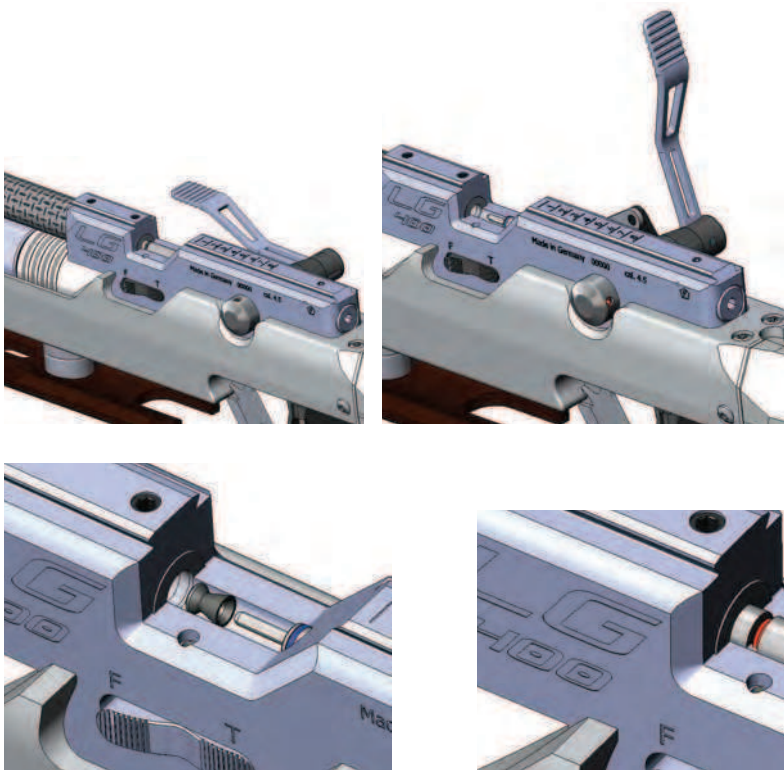

Place the pellet into the loading recess as shown in the figure and close the loading lever until it is parallel with the receiver again or has engaged.

The red mark on the loading pin shows that your weapon is loaded. When the trigger is pulled, the pre-cocked striker is released and opens the valve of the firing chamber. The pre-compressed air then propels the pellet out of the barrel.

Caution: Never put down a loaded gun. Never carry a loaded weapon on your person.

Caution: If the gun falls in a loaded or safety-off condition, the impact may cause a shot to be discharged.

5 Unloading

Remove the pellet by pointing the muzzle in a safe direction and discharging the shot. Observe the safety instructions.

Caution: Before performing any adjustment, assembly, care or cleaning work, always check the gun to be sure it is unloaded and the barrel is free of pellets and foreign matter. Always wear protective eyewear.

6 Trigger

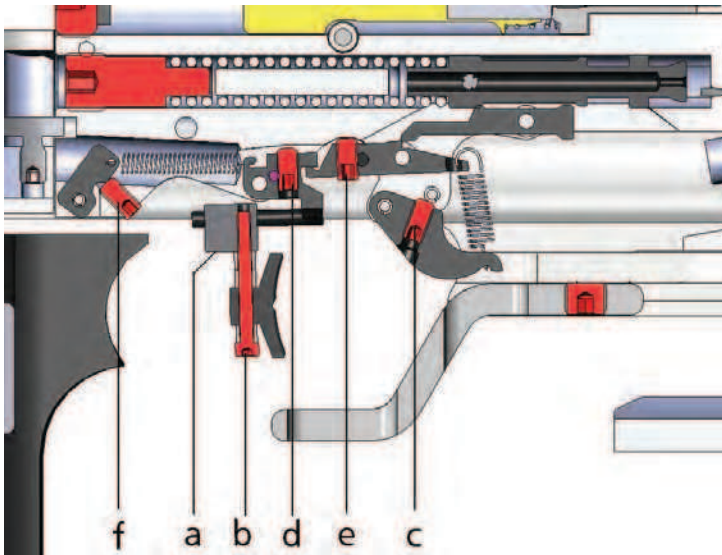

Trigger finger piece

The trigger finger piece can be individually adjusted according to the shooter's trigger finger. After the screw (a) has been loosened, the trigger finger piece can be pushed forward or pulled back on the guide and can also be pivoted sideways. Elevation is adjusted by loosening the screw (b) and moving the spacer rings. The trigger finger piece is designed so that it can be used by both left-handed and right-handed marksmen.

First stage travel

The first stage travel, i.e. the path of the trigger finger piece up to the let-off point, can be individually adjusted. Turning the screw (d) to the right (clockwise) reduces the first stage travel. Turning the screw to the left (counterclockwise) produces a longer first stage travel.

First stage trigger weight

Adjust the first stage trigger weight using the screw (f). Turn it to the right (clockwise) to increase the first stage trigger weight, and turn it to the left (counterclockwise) to reduce it.

Second stage trigger weight

Adjust the second stage trigger weight using the screw (c). Turn it to the right (clockwise) to increase the second stage trigger weight, and turn it to the left (counterclockwise) to reduce it.

Let-off point

The let-off point is set at the factory to the optimal setting. If a correction is required, then by turning the screw (e) to the right (clockwise), you can achieve a crisp, direct trigger let-off point. Turning the screw to the left (counterclockwise) sets a "sluggish" let-off point. With the trigger cocked, turn the screw (e) slowly to the right (clockwise) until the striker is released. Then turn the screw back about $\frac{1}{4}$ to $\frac{1}{2}$ of a turn.

Caution: Always close the loading lever with care, especially when you have a very crisp setting for the trigger action. This ensures that the trigger won't fire by itself, without being touched.

Direct trigger

To set the trigger to "direct", that is without first stage travel, turn the screw (e) at least two rotations further to the left (counterclockwise) than described above for

an optimal let-off point. Then set the let-off point using the screw (d) as described above.

Caution: Triggers set for direct action are very sensitive and should be operated with great care. Setting the trigger pull weight to a minimum and using a very dry let-off point can cause malfunctions and create a safety risk (inadvertent firing).

7 Setting for dry firing

To change to dry firing and back, you must cock the trigger. Use the rocker switch to change back and forth.

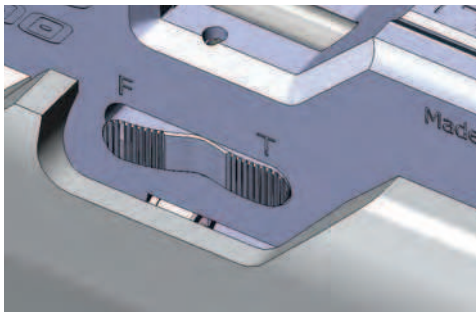

Position: F: Firing

Position T: Training (dry firing)

8 Sights

Diopter

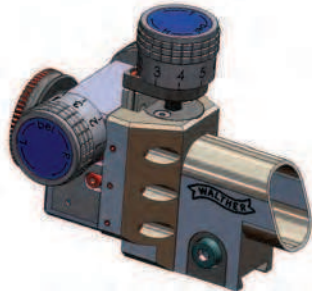

"Insight-Out" sight

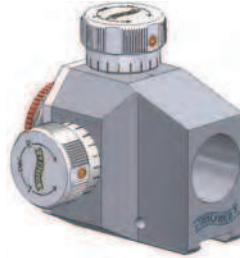

Standard sight

To attach

Push the sight on the dovetail rail and tighten hand-tight at the required eye base. Avoid overtightening.

Elevation and windage adjustment

Use the two knobs to make adjustments. One click moves the impact point by 0.4 mm (competition sight) or 0.6 mm (standard sight) at 10 m distance.

Elevation adjustment

- If shots group high, turn the knob clockwise.
- If shots group low, turn the knob counterclockwise.

Windage adjustment

- If shots group to the right, turn the knob clockwise.
- If shots group to the left, turn the knob counterclockwise

We recommend that you set the two knobs to position "0" (competition sight only) after sighting in the rifle. To do this, lift them slightly and move them to the desired position.

Excessive turning when making adjustments will impair the accuracy and possibly damage the sight.

Foresight holder



Centra Score foresight holder

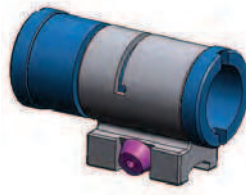

Standard foresight holder

Push the sight on the dovetail rail and tighten hand-tight at the required distance. To change the foresight, open the rear knurled screw, remove the foresight, put in the new one and retighten the screw.

9 Compressed air supply / compressed air cylinder

The LG400 air rifle is equipped with a screw-on/screw-off compressed air cylinder which is approved for compressed air **up to 300 bar**. This cylinder can be unscrewed, filled or changed at any time. **Caution: the compressed air cylinder and pressure reducer should be assembled and disassembled only by authorized specialists.**

Filling the compressed air cylinder

When refilling, use only oil- and water-free compressed air with a maximum pressure of 300 bar (DIN EN 12021 – breathing air). Never expose filled pressure cylinders to a temperature above 50° C. Do not make alterations to the compressed air cylinder or its valves. The provisions of the TRG (technical regulations relating to pressurized gas) for filling compressed air cylinders must be complied

with. Observe applicable national statutory regulations for refilling. Do not refill cylinders which are leaky or otherwise unsafe. Empty them in a safe manner.

Screw the supplied adapter onto the refill cylinder or compressor and tighten it. Unscrew the compressed air cylinder from the rifle and then screw it onto the adapter of the refill cylinder. Slowly open the valve of the refill cylinder and close it again after about 1 minute. Screw off the filled compressed air cylinder and firmly screw it onto the rifle by hand until it stops.

Compressed air cylinders must never be used or stored above maximum pressure.

Emptying the compressed air cylinder

The compressed air cylinder can be emptied with the supplied adapter. Screw the adapter onto the compressed air cylinder until air can be heard flowing out.

Compressed air cylinders which are leaky, damaged or more than 10 years old should be emptied in a safe manner and not used or filled again. Ten years after the manufacturing date, the compressed air cylinder must be tested at the owner's expense or replaced. The manufacturing date is recorded on the cylinder. See also section on service life.

Removing the compressed air cylinder

Owing to improvement of the air supply system, air can remain in the pressure reducer after the compressed air cylinder has been removed. It may take some time (five to ten seconds) for this residual air to escape.

After you have removed the compressed air cylinder, we recommend for reasons of safety that you cock the weapon and pull the trigger to allow the residual air to escape. Repeat this process once or twice if necessary. When doing so, always point the weapon away from other people and make sure that there is no pellet in the barrel. If you use your air rifle at regular weekly intervals, you do not need to unscrew the compressed air cylinder when you have finished shooting. If you do not expect to use the weapon for a period of more than two to three weeks, you

should remove the compressed air cylinder so that the system is no longer under pressure. This prolongs the life of the seals. We accept no responsibility for any damages arising from alteration of parts, use of parts other than original Walther parts or failure to follow the operating instructions.

Service life

The maximum permissible service life of compressed air cylinders made by Carl Walther GmbH & Produktions KG depends on whether they are made of aluminum or of steel.

Service life of compressed air cylinders made of aluminum:

Past experience and further testing using the latest technology available indicate that the manufacturer-specific service life of aluminum compressed air cylinders should be limited to 10 years. This ensures a maximum degree of safety for users and third parties.

Out of concern for users and third parties, we cannot recommend prolonging the service life of aluminum cylinders through "reconditioning" or "inspection" that involves pressure tests but does not include investigation of their internal structure (especially microstructure). In view of the many years of stress on the material (including especially possible damage, alteration and improper use), such tests cannot give a 100% guarantee that aluminum cylinders are safe to use for an extended period.

For this reason, compressed air cylinders made of aluminum must not be used if they are more than 10 years old (according to the manufacturing date shown on the cylinders). Empty them in a safe manner.

Service life of compressed air cylinders made of steel:

For compressed air cylinders made of steel, a limited service life of 10 years also applies. Owing to their different characteristics, the manufacturer provides the option of retesting them after 10 years. If no defects are discovered in this test, the

service life can be extended a single time for another 10 years. Thus a total maximum service life of 20 years is possible.

The service life of a compressed air cylinder that is more than 20 years old cannot be extended by means of repeated testing. When the maximum permissible service has been reached, the cylinder must be emptied in a safe manner and discarded.

Additional important information on the use of compressed air cylinders

- If you transport a compressed air cylinder by airplane or send it by mail, it must be empty.
Check the pressure level indicator of a compressed air cylinder only when your air rifle is unloaded and decocked. The pressure level indicator has an accuracy of $\pm 10\%$. Temperature variations can also affect the level shown.
- Repairs on compressed air cylinders must be carried out only by the manufacturer, using original replacement parts. In the case of noncompliance the manufacturer shall have no liability and the warranty shall be null and void.
- Do not alter the surface of the compressed air cylinder. In particular, do not engrave it or apply abrasives. This can damage the cylinder and create a safety risk.
- Inspect the compressed air cylinder for cracks and damage before each use.
- Protect the compressed air cylinder against damage of any kind.

10 Changing the butt stock / cast **(Alutec only)**

The stock is divided, allowing the butt stock to be replaced by other variants (special accessories). In addition, this allows the butt stock to be moved laterally by eight millimeters to the left or right. To do this, remove the entire cheek

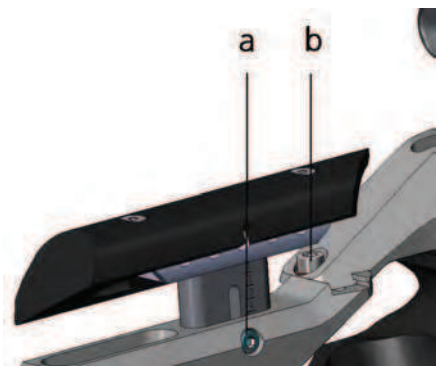

piece by loosening the screw (a). Then loosen the screw (b). The butt stock can now be moved or removed/replaced. To attach a new butt stock, reverse the steps.

11 Adjusting the butt plate and stock length

LG400 Anatomic & LG400 Alutec Expert

To alter the stock length, undo the clamping screw (a), after which the stock

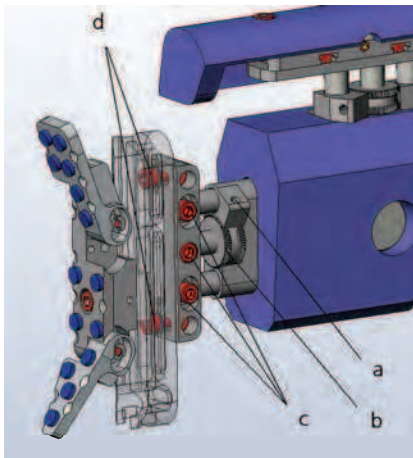

length can be varied by turning the setting wheel (b). Then retighten the setting wheel (b) using the clamping screw (a). If the stock length cannot be extended far enough, a longer stock can be obtained by using longer rods (special accessory).

To alter the cheek piece inclination, undo the clamping screws (c). It may first be necessary to undo the clamping screw (a) and to turn the setting wheel (b) towards the butt plate so that the rods can move freely.

It is also possible to move the butt plate to the side. In this connection, be sure to comply with the sports rules. If the butt plate has to be moved, undo the fastening screws (d). Retighten them once the butt plate is in the required position.

- Shortest possible setting ranges for shooters/juniors more than 160 cm tall
- Simple release and locking of the stock length
- Knurled screw permits adjustment with millimeter accuracy
- Independent adjustment of butt plate and butt plate attachment
- Removal and fitting in a single operation

LG400 Alutec Competition & LG400 Alutec Basic

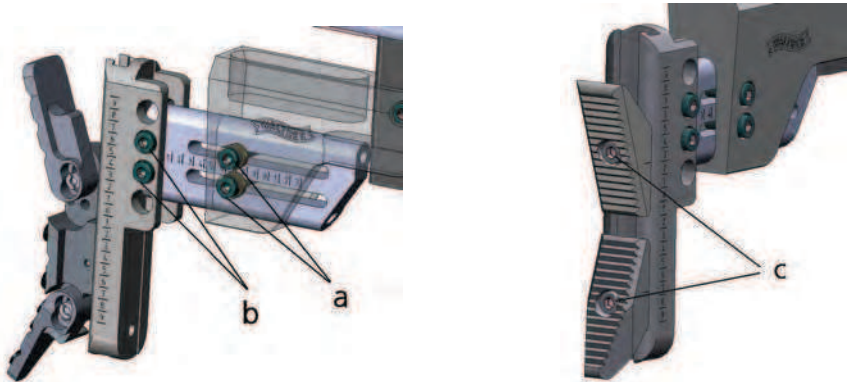

To set the shaft length, loosen the screws (a). To set the butt plate inclination, loosen the two screws (b).

To change the position of the butt plate wings individually, loosen the screws (c). If you remove the two wings, you can attach an MEC butt plate (special accessory) in their place.

12 Adjusting the cheek piece

LG400 Anatomic & LG400 Alutec Expert

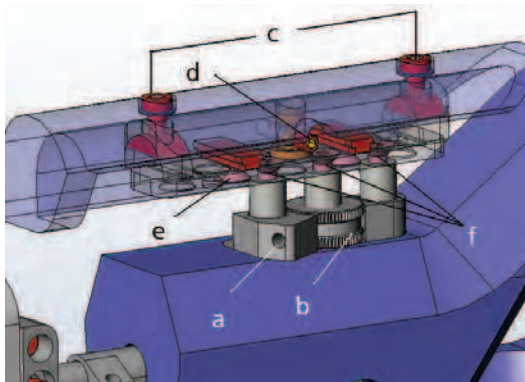

The cheek piece has a wide variety of possible adjustments, most of which can be made in the shooting position. To adjust the **cheek piece height**, undo the clamping screw (a), then alter the height of the cheek piece using the setting wheel (b).

The **lateral displacement** of the cheek piece can also be performed conveniently in the shooting position using the clamping screw (d). When the latter is undone, the cheek piece can be pushed towards or away from the face. After adjustment, retighten the clamping screw (d).

The **cheek piece inclination** can be altered by undoing the clamping screws (c) and by rotation about the longitudinal axis, followed by retightening of the clamping screws (c).

To **reposition** the cheek piece forwards or rearwards in the **longitudinal direction**, remove the countersunk screws (e) and move the sliding blocks in the required direction. The best way to do this is to remove the complete cheek piece from the stock (undo screw (a) and remove cheek piece) and the top part of the cheek piece (undo screw (d) and pull off cheek piece to the side).

Another **option** for **longitudinal adjustment** is to move the guide rods; to do so, remove the countersunk screws (f) and reposition the rail. It is recommended to leave the guide rods in their block during this assembly process, as this is the only way to ensure correct alignment.

Tip: The lateral cheek piece contact should if possible be in a straight line with the barrel axis.

- All functions accessible in the shooting position
- Height adjustment using knurled screw
- Bench rest cheek piece with special rear shape
- Easy setting of height, side and length

LG400 Alutec Competition & LG400 Alutec Basic

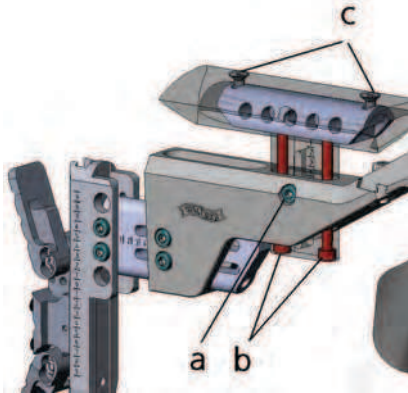

The cheek piece can be individually adjusted in many ways. To adjust the height, loosen the screw (a) and retighten it after completing the adjustment. To adjust the cast (lateral offset), loosen the screw (b). Use the screw (c) to adjust the inclination. To **reposition** the cheek piece forwards or rearwards, remove the countersunk screws (c) and move the threaded pins in the required direction.

The best way to do this is to first remove the complete cheek piece from the stock (undo screw (a) and remove cheek piece).

13 Adjusting the grip

LG400 Anatomic & LG400 Alutec Expert & LG400 ALUTEC Competition

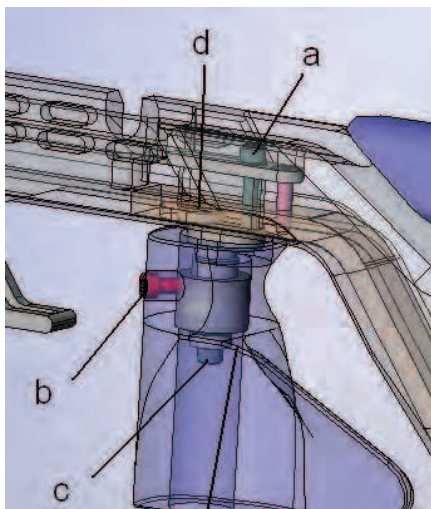

The grip is fastened to a ball-and-socket joint, allowing every possible movement about this center-point. In addition, the position of the grip can be moved in the longitudinal direction, sideways and in its height. For **longitudinal adjustment** and **lateral displacement**, undo screw (a) and move the grip to the required longitudinal and lateral position. Lateral displacement is achieved by turning the eccentric disk from above.

Then fix this setting using the screw (a).

Change the **height** of the grip by undoing the clamping screw (b). Ensure here that the screw (b) is flush with the flat surface of the grip.

Set the **three-dimensional inclination** and **rotation out of the middle plane** of the grip using the ball-and-socket joint which is fixed by the screw (c). To alter the setting, undo the screw (c), set the required position of the grip and lock it in this position by retightening the screw.

Tip: Avoid displacing the grip too far to the side, in order to minimize faults when the trigger is pulled.

- Optimum grip ergonomics
- 3D-settable
- Interchangeable grip sizes
- Left-hand and right-hand versions

LG400 Alutec BASIC

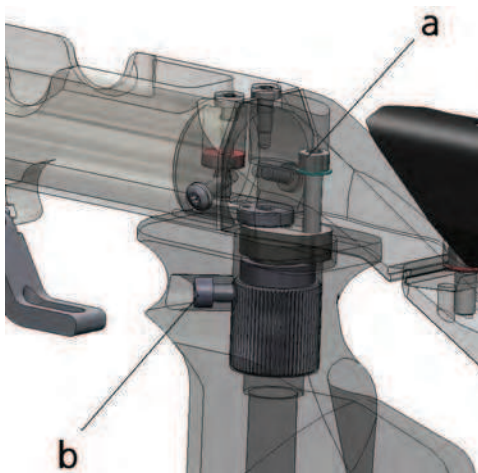

The basic grip adjustment has the same possibilities as the expert grip adjustment, with the exception of the 3D ball-and-socket adjustment. To adjust the grip longitudinally and laterally, loosen the clamping screw (a). To adjust the height, loosen the screw (b).

14 Fore-end elevation for shooting in the standing position

LG400 Anatomic & LG400 Alutec Expert

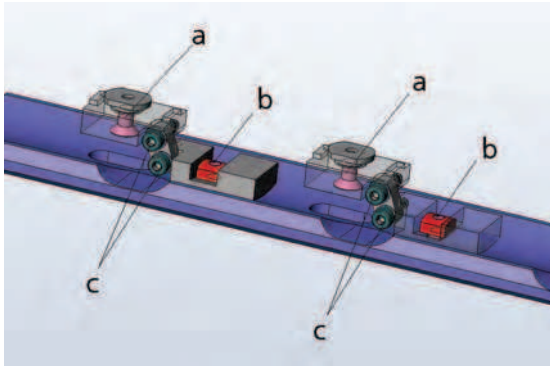

The fore-end elevation for shooting in the standing position can be adjusted in the longitudinal direction, in its height and in its inclination. It can also be swiveled about the barrel axis.

To **reduce or increase** the fore-end elevation in the

longitudinal direction, undo the countersunk screws (a). This unclamps the holding rail. Adjust the **fore-end height and the inclination angle** using the clamping screws (c). Slightly undo all screws (c), set the required height and inclination, then retighten the screws (c). To **swivel the fore-end** transversely to the direction of shooting, undo the screws (b). After positioning, retighten the screws (b).

- Mutually independent settings of height, inclination and lateral swivel.
- Ergonomically optimum width of 50 mm
- Rough-textured coating for a sure grip

LG400 Alutec Competition & LG400 Alutec Basic

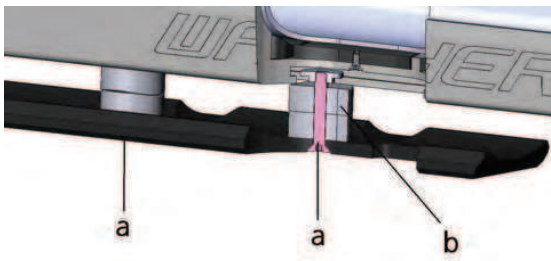

The standard fore-end elevation can be moved in the longitudinal direction and adjusted in two steps in the vertical direction. To remove it from the stock, undo the screws (a). Removing the spacers (b) reduces the height by 10 mm. In this case the shorter countersunk screw (a), which is supplied as an accessory, must be used for clamping.

15 Fore-end for shooting from a rest

LG400 Anatomic

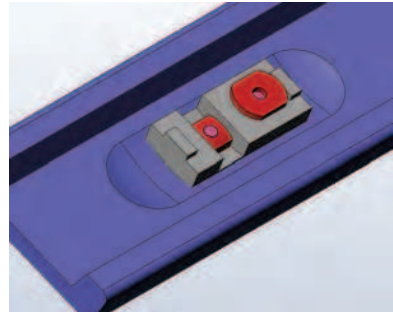
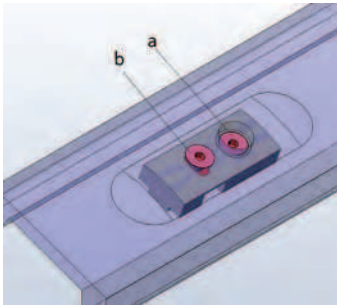

The Senior fore-end for bench rest shooting is fastened to the holding rail of the stock with sliding blocks. Undo the screws (a) and slide the blocks together with the fore-end onto the rail. Then clamp the fore-end by tightening the screws (a). The entire fore-end can be swiveled in the transverse direction by undoing the screws (b).

- Maximum permissible width of bench rest surface
- Infinite lateral swivel in both directions
- Easy to fit and to remove
- Resting point near the muzzle

LG400 Alutec (Basic & Expert)

The model Alutec, which has an aluminum stock, can be converted into an air rifle for DSB bench rest shooting by fitting it with a stock extension and a Senior fore-end.

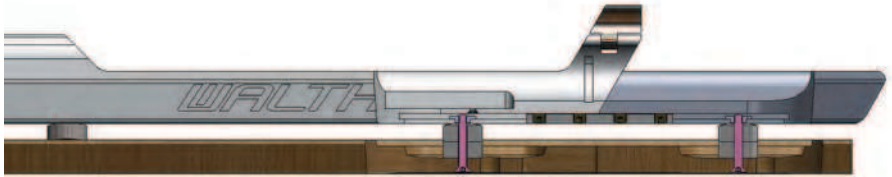

For this purpose, first remove the fore-end for shooting in the standing position and pre-mount the Senior fore-end (g) and the stock extension (f) as shown below.

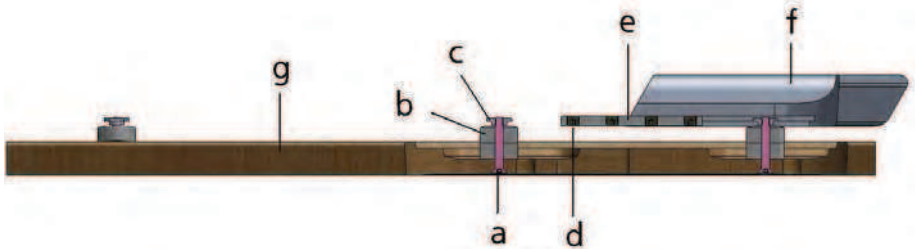

- Insert the strip (e) into the T-groove of the stock extension (f) and center it at the back edge of the stock extension (f). Tighten both clamping screws (d).
- Push the stock extension (f) over the T-groove onto the sliding block of the Senior fore-end (g).
- Then push the Senior fore-end (g) together with the stock extension (f) onto the stock of the air rifle. In doing so, make sure that the sliding blocks (c) and the strip (e) come to rest in the T-groove of the stock.
- Press the stock extension (f) onto the stock of the air rifle and secure it in place with the clamping screws (e).
- Move the Senior fore-end (g) into the correct position and tighten it with the three clamping screws (a).

Follow the same procedure to attach the Senior fore-end with Expert double joint.

16 Chest rest for butt plate

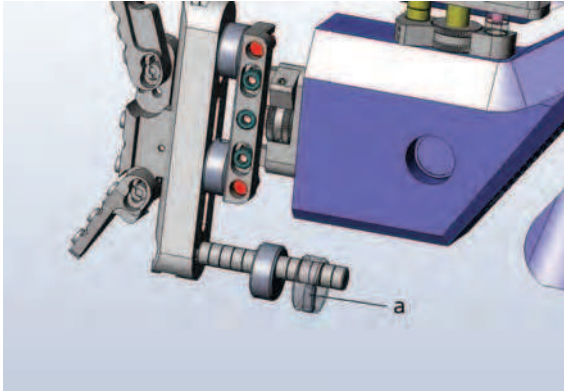

To align the stock optimally with the body, offset-holed special steel discs can be mounted on the butt plate rod. For setting, undo the set screw (a), align the disc in its longitudinal direction and in its lateral displacement, and retighten it using the set screw (a).

Tip: If the rifle has to be heavier in the butt stock area, with the centre of gravity being shifted to the rear, several steel discs can be mounted on the rod. It is also possible to position these discs between the butt plate and the butt plate attachment (Anatomic & Expert).

The specifications of the ISSF sports ordinance must be observed with all settings on the stock.

17 Accessories

- Various tools
- Filling adapter for compressed air pump
- Operating instructions
- Plastic gun case
- Cleaning set
- Test target
- Safety flags

18 Equipment / special accessories

		Anatomic Expert	Alutec Expert	Alutec Competition	Alutec Basic
278 13 44	EXPERT aluminum butt stock with precision stock length and cheek piece adjustment with CONTACT III MEC aluminum butt plate	-	x	o	o
278 14 33	COMPETITION aluminum butt stock with quick stock length and cheek piece adjustment with CONTACT III aluminum butt plate	-	o	x	o
278 13 36	BASIC aluminum butt stock with quick stock length and cheek piece adjustment with Walther SINUS aluminum butt plate	-	o	o	x
277 71 93	CONTACT III MEC aluminum butt plate	x	x	x	o
278 13 52	Walther SINUS aluminum butt plate wings	o	o	o	x
278 29 61	Cheek piece rods, long, assy. (including spindle)	o	x	-	-
278 29 79	Cheek piece rods, short, assy. (including spindle)	x	o	-	-
278 29 87	Butt plate rods, long, assy. (including spindle)	o	o	-	-
278 29 95	Butt plate rods, short, assy. (including spindle)	x	x	-	-
278 29 44	Cheek piece slide, short	-	-	o	o
277 55 65	Cheek piece slide, long	-	-	x	x
278 29 52	Butt plate slide, short	-	-	o	o
276 14 24	Butt plate slide, long	-	-	x	x
276 08 51	Walther INSIGHT-OUT competition sight	x	x	x	o
264 42 23	Walther standard competition sight	o	o	o	x
265 98 67	SCORE Centra foresight holder	x	x	x	o
2.4827	Walther standard foresight holder	o	o	o	x
	EQUALIZER magnet absorber system	x	x	x	o
	QUICKCLEAN air filter	x	x	x	x

LG400 – Operating Instructions



278 15 73	Magnet absorber system upgrade kit	o	o	o	o
276 17 77	Loading status indicator upgrade kit	o	o	o	o
276 02 91	3D grip adjustment	x	x	x	o
276 15 13	Basic grip adjustment	o	o	o	x
276 01 93	Laminated wood grip, size S	o	-	-	-
275 18 79	Laminated wood grip, size M	x	-	-	-
276 01 77	Laminated wood grip, size L	o	-	-	-
278 12 80	PROTOUCH wood grip, size S	-	o	o	o
277 64 48	PROTOUCH wood grip, size M	-	x	x	x
278 12 98	PROTOUCH wood grip, size L	-	o	o	o
275 18 52	Laminated wood fore-end, short, with double joint	x	-	-	-
278 13 95	PROTOUCH wood fore-end, short, with double joint	-	x	o	o
278 14 09	PROTOUCH wood fore-end, short	-	o	o	x
278 17 21	Aluminum fore-end extension for bench rest shooting	-	o	o	o
275 22 63	Senior laminated wood fore-end with double joint	o	-	-	-
278 14 17	Senior PROTOUCH wood fore-end with double joint	-	o	o	o
278 14 25	Senior PROTOUCH wood fore-end	-	o	o	o
277 59 05	Walther VARIO trigger	x	x	x	x
276 17 18	Aluminum compressed air cylinder, silver, 300 bar	x	x	x	x
267 13 79	Aluminum compressed air cylinder, black, 300 bar	o	o	o	o
263 31 67	Steel compressed air cylinder, black, 300 bar	o	o	o	o
266 48 52	Maxi steel compressed air cylinder, black, 300 bar	o	o	o	o
262 07 15	Refill cylinder, 300bar	o	o	o	o
275 31 38	Chest rest, 30 g	2	2	o	o
278 13 28	Fore-end weight, 50 g	-	x	x	o
266 80 25	Barrel jacket weight, 100 g	o	o	o	o
278 13 10	Barrel weight, 30 g	x	x	o	o
273 01 94	Centra BLOCK CLUB raised line of sight	x	x	o	o
273 04 81	Walther plastic gun case	x	x	x	x

x = standard, o = optional, - = not available

19 Technical data

	Anatomic Expert	Alutec Expert	Alutec Competition	Alutec Basic
Compressed air system	300 + 200 bar	300 + 200 bar	300 + 200 bar	300 + 200 bar
Caliber	.177 (4.5 mm)	.177 (4.5 mm)	.177 (4.5 mm)	.177 (4.5 mm)
Stock (system carrier)	Laminated wood	Aluminum	Aluminum	Aluminum
Distance from trigger finger piece to butt plate **	310-390	310-390	310-390	290-370
Length (mm)	1075-1100	1075-1100	1075-1100	1075-1100
Height (mm)	290	290	290	280
Width (mm) (without loading lever)	50	50	50	50
Weight (g)	4400	4300	4200	4100
Trigger pull weight (g)	50-120	50-120	50-120	50-120
Sight length (mm)	650-850	650-850	650-850	650-850
Barrel length (mm)	420	420	420	420
Cylinder capacity	approx. 500	approx. 500	approx. 500	approx. 500

** For other ways to change the stock length, see section on special accessories.